

BASIC SERIAL COMMAND

FUNCTIONAL SPECIFICATIONS

PLV-Z3000

Ver.1.00

CONTENTS

1. Overview	5
2. Serial Interface Specification	5
3. Connection.....	5
4. Notes for Communication	6
5. Functional Execution Command Table.....	7
6. Status Read Command Table.....	9
7. Functional Execution Command	10
7.1. Format	10
7.2. Command Pipelining	10
7.3. Transfer Example	10
7.4. Operation Requirements	11
7.5. POWER ON Command	12
7.6. POWER OFF Command (QUICK POWER OFF)	12
7.7. POWER OFF Command.....	12
7.8. VIDEO MUTE ON Command	12
7.9. VIDEO MUTE OFF Command.....	12
7.10. Screen Normal size Command	13
7.11. Screen Full size Command	13
7.12. Image Living Command.....	13
7.13. Image Creative Cinema Command.....	13
7.14. Image Pure Cinema Command	13
7.15. Image 1 Command	13
7.16. Image 2 Command	13
7.17. Image 3 Command	14
7.18. Image 4 Command	14
7.19. Image Brilliant cinema Command	14
7.20. Image Dynamic Command	14
7.21. Image Natural Command	14
7.22. MENU ON Command.....	14
7.23. MENU OFF Command.....	14
7.24. DISPLAY CLEAR Command	15
7.25. Image x.v. Color Command	15
7.26. Video Source VIDEO Command	15
7.27. Video Source S-VIDEO Command.....	15
7.28. Video Source COMPONENT 1 Command	15
7.29. Video Source COMPONENT 2 Command	15
7.30. Power Management ON Command	15
7.31. Power Management OFF Command	16
7.32. Screen Zoom size Command	16

7.33.	Screen Natural wide size Command	16
7.34.	Image 5 Command	16
7.35.	Image 6 Command	16
7.36.	Image 7 Command	16
7.37.	Point Right Command.....	17
7.38.	Point Left Command	17
7.39.	Point Up Command	17
7.40.	Point Down Command.....	17
7.41.	ENTER Command.....	17
7.42.	RESET Command.....	17
7.43.	BACK Command	18
7.44.	FREEZE ON Command	18
7.45.	FREEZE OFF Command	18
7.46.	Factory default Command.....	18
7.47.	Computer Source Analog RGB Command	18
7.48.	Computer Source Scart Command	18
7.49.	HDMI 1 Command.....	19
7.50.	HDMI 2 Command.....	19
7.51.	Screen Anamorphic size Command.....	19
7.52.	Lamp mode AUTO 1 Command	19
7.53.	Lamp mode AUTO 2 Command	19
7.54.	Lamp mode NORMAL Command.....	19
7.55.	Lamp mode ECO Command.....	19
7.56.	Ceiling ON Command	20
7.57.	Ceiling OFF Command.....	20
7.58.	Rear ON Command	20
7.59.	Rear OFF Command.....	20
7.60.	Logo OFF Command.....	20
7.61.	Logo Default Command.....	20
7.62.	Logo User Command.....	20
7.63.	Logo Capture Command	21
7.64.	My Picture ON Command	21
7.65.	My Picture OFF Command	21
7.66.	AUTO PC Adjust Command	21
8.	Status Read Command	22
8.1.	Format	22
8.2.	Transfer Example	22
8.3.	Status Read Command.....	22
8.4.	Input Mode Read Command	25
8.5.	Lamp Time Read Command.....	25

8.6. Setting Read Command	25
8.7. Temp Read Command	26

1. Overview

- 1.1 These specifications define projector control commands for PLV-Z3000.
- 1.2 The projector control commands are used to control a projector through RS-232C from a computer.

2. Serial Interface Specification

Items	Specification
Synchronous system	Asynchronous
Transmission Speed	9600 / 19200
Data Length	8 bit
Parity	N/A
Stop Bit	1
Flow Control	N/A

- 1) Transmission speed: initial setting value is 19200.
- 2) Transmission speed can be changed in service mode.

3. Connection

Dedicated serial cable must be used for a connection to a computer and a projector.

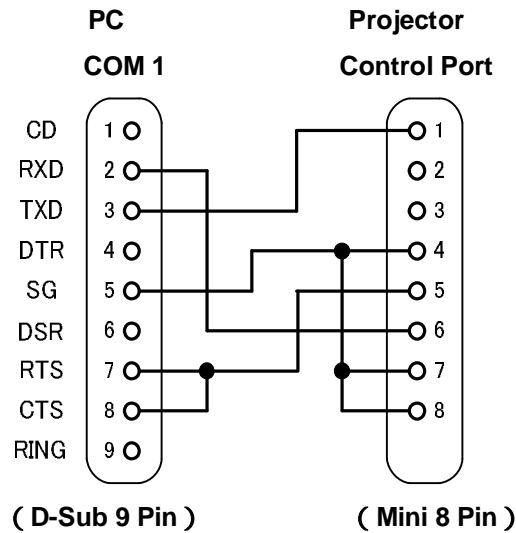

4. Notes for Communication

- I. The projector command is defined as one command/one line that starts with "C" and ends with carriage return (0x0D).
- II. When the projector receives carriage return, it starts decoding.
- III. There are two types of commands: Functional Execution Commands and Status Read Commands.
 1. Example of Functional Execution Command: "C05" [CR]
 2. Example of Status Read Command: "CR0" [CR]
- IV. It clears the information of buffer as below.
- V. The projector receives LF (0x0A) or EOF (0x1A).
- VI. When it takes more than one second to receive one command.
(Until the projector returns carriage return since it has received the first data.)
- VII. When control command pipelining, wait the interval of time after the response as below.
- VIII. [VOLUME +/-] Commands \longrightarrow 100ms
- IX. Other Commands \longrightarrow 500ms
- X. When Status Read command pipelining, wait at least 500ms after the response.
- XI. Do not issue any command before receiving the response except there is no response for 5 seconds.
- XII. It takes about 7 seconds for the internal initialization after plugging in AC. During this time, it cannot process commands. Do not issue any command.
- XIII. For 7 seconds after Power ON from Standby, the projector receives a command and returns the response but does not execute it because of the internal initialization or Lamp processing. However, Status Read Commands are carried out after 500 ms when receiving the response to Power ON command.
- XIV. About Count Down and the performance during Cooling Down:
 1. When receiving a command during Count Down after Power ON or Cooling Down after Power OFF, the projector returns the response but does not carry it out. However, Status Read Commands are carried out.
- XV. The performance for switching Input:
 1. It takes 5 seconds to switch Input after receiving the command. When receiving the command during this time, it is not executed. However, Status Read Commands are carried out after 500ms since it receives the response to switching Input command.
- XVI. The number of character of response to Status Read Commands depends on commands. Please see [8. Status Read Commands].
- XVII. Characters for commands must be Capital (A - Z).

5. Functional Execution Command Table

Command	Item	Command	Item
C00	POWER ON	C28	-----
C01	POWER OFF (QUICK POWER OFF)	C29	-----
C02	POWER OFF	C2A	Power Management ON
C03	-----	C2B	Power Management OFF
C04	-----	C2C	Screen Zoom size
C05	-----	C2D	Screen Natural wide
C06	-----	C2E	-----
C07	-----	C2F	-----
C08	-----	C30	-----
C09	-----	C31	-----
C0A	-----	C32	-----
C0B	-----	C33	-----
C0C	-----	C34	-----
C0D	VIDEO MUTE ON	C35	-----
C0E	VIDEO MUTE OFF	C36	Image 5
C0F	Screen Normal size	C37	Image 6
C10	Screen Full size	C38	Image 7
C11	Image Living	C39	-----
C12	Image Creative Cinema	C3A	Point Right
C13	Image Pure Cinema	C3B	Point Left
C14	Image 1	C3C	Point Up
C15	Image 2	C3D	Point Down
C16	Image 3	C3E	-----
C17	Image 4	C3F	ENTER
C18	-----	C40	RESET
C19	Image Brilliant cinema	C41	BACK
C1A	Image Dynamic	C42	-----
C1B	Image Natural	C43	FREEZE ON
C1C	MENU ON	C44	FREEZE OFF
C1D	MENU OFF	C45	-----
C1E	DISPLAY CLEAR	C46	-----
C1F	Image x.v.Color	C47	-----
C20	-----	C48	-----
C21	-----	C49	-----
C22	-----	C4A	-----
C23	Video Source Video	C4B	-----
C24	Video Source S-Video	C4C	Factory default
C25	Video Source Component 1	C4D	-----
C26	Video Source Component 2	C4E	-----
C27	-----	C4F	-----

“-----” means “No Function”.

Command	Item	Command	Item
C50	Computer (Analog RGB)	C78	Rear ON
C51	Computer (Scart)	C79	Rear OFF
C52	-----	C7A	Logo OFF
C53	HDMI 1	C7B	Logo Default
C54	HDMI 2	C7C	Logo User
C55	-----	C7D	Logo Capture
C56	-----	C7E	My Picture ON
C57	-----	C7F	My Picture OFF
C58	-----	C80	-----
C59	-----	C81	-----
C5A	-----	C82	-----
C5B	-----	C83	-----
C5C	-----	C84	-----
C5D	-----	C85	-----
C5E	-----	C86	-----
C5F	-----	C87	-----
C60	-----	C88	-----
C61	-----	C89	Auto PC Adj.
C62	-----	C8A	-----
C63	-----	C8B	-----
C64	-----	C8C	-----
C65	-----	C8D	-----
C66	-----	C8E	-----
C67	-----	C8F	-----
C68	-----	C90	-----
C69	-----		
C6A	-----		
C6B	-----		
C6C	-----		
C6D	-----		
C6E	-----		
C6F	-----		
C70	-----		
C71	-----		
C72	Lamp mode Auto 1		
C73	Lamp mode Auto 2		
C74	Lamp mode Normal		
C75	Lamp mode Eco		
C76	Ceiling ON		
C77	Ceiling OFF		

“-----” means “No Function”.

6. Status Read Command Table

Command	Item	Memo
CR0	Status Read	
CR1	Input Mode Read	
CR2	-----	
CR3	Lamp Time Read	
CR4	Setting Read	
CR5	-----	
CR6	Temp Read	

“-----” means “No Function”.

7. Functional Execution Command

7.1. Format

PC issues a command in format as below.

"C" COMMAND [CR]

Command: two characters (See Basic Functional Execution Command Table)

A projector changes received data to decode and returns a result after being ready to receive next command.

[ACK] [CR]: (0x06, 0x0D) When received Functional Execution Commands.

"?" [CR]: When the received data cannot be decoded.

7.2. Command Pipelining

When some functions need the command pipelining, the performance is the same as that of the remote control.

7.2.1. System: issue any command every 100 ms.

7.2.2. When receiving the appropriate command, the function is executed for 120 ms from the moment.

7.2.3. When receiving the same command continuously within 120 ms, the function is executed for another 120 ms from the moment.

7.2.4. When there is no incoming command after 120 ms, the execution of pipelining is stopped.

7.2.5. When the projector receives other incoming commands within 120ms, the execution of pipelining is stopped.

7.3. Transfer Example

Switch input mode for the projector to Video Mode with Basic Command.

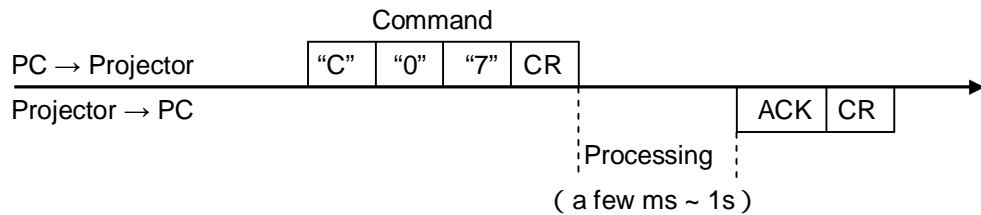

7.4. Operation Requirements

The projector cannot return any response for about two seconds after AC power ON because of the initialization.

When the projector's status is as below, Functional Execution Commands are limited.

(Status Read Commands are available in this status except Standby Mode)

Projector Mode	Available Functional Execution Commands
Super Standby Mode	Impossible to respond
Normal Standby Mode	CR6 : Temperature information read command is unavailable (Commands related to S5V series are also unavailable)
Processing Cooling Down	C00 : POWER ON (Countdown is terminated)
Cooling Down due to Abnormal Temperature	NONE
Abnormal Temperature Status	NONE
Abnormal Power Status	NONE
Switching Mode	NONE
Processing Power Save / Cooling Down	NONE
Processing Logo Capture / Displaying Captured Logo	NONE
Power Save Status	Only key operation commands are available

Note) When the status is any of above, projector returns **[ACK] [CR]** even if it receives other commands,

7.5. POWER ON Command

Command	"C00" [CR]	
Details	Power ON the projector. When already Power is ON, the command is invalid. When sending this command during processing Countdown, Countdown is terminated	
Response	Acceptable	[ACK] [CR]
	Unacceptable	" ? "[CR]

7.6. POWER OFF Command (QUICK POWER OFF)

Command	"C01" [CR]	
Details	Power OFF (Standby) the projector. When using ON/Stand-by button of the projector or the remote control to turn off the projector, "Power Off?" message is displayed before operation. However, as soon as this command is sent, Quick Power OFF is executed	
Response	Acceptable	[ACK] [CR]
	Unacceptable	"?"[CR]

7.7. POWER OFF Command

Command	"C02"[CR]	
Details	Power off (Standby) the projector. This command works the same as ON/Stand-by button of the projector and the remote control (When sending this command, "Power OFF?" message is displayed on the screen. Power OFF is executed by resending this command during the message is shown,)	
Response	Acceptable	[ACK] [CR]
	Unacceptable	"?"[CR]

7.8. VIDEO MUTE ON Command

Command	"C0D"[CR]	
Details	Black out the image This command works the same as "NO SHOW" button of the remote control, but it does not operate No Show OFF	
Response	Acceptable	[ACK] [CR]
	Unacceptable	"?"[CR]

7.9. VIDEO MUTE OFF Command

Command	"C0E"[CR]	
Details	Release the Black out This command works the same as "NO SHOW" button of the remote control, but it does not operate No Show On	
Response	Acceptable	[ACK] [CR]
	Unacceptable	"?"[CR]

7.10. Screen Normal size Command

Command	"C0F"[CR]	
Details	Set Computer / Video screen size to Normal	
Response	Acceptable	[ACK] [CR]
	Unacceptable	"?"[CR]

7.11. Screen Full size Command

Command	"C10"[CR]	
Details	Set Computer / Video screen size to Full screen	
Response	Acceptable	[ACK] [CR]
	Unacceptable	"?"[CR]

7.12. Image Living Command

Command	"C11"[CR]	
Details	Set Image to Living Mode	
Response	Acceptable	[ACK] [CR]
	Unacceptable	"?"[CR]

7.13. Image Creative Cinema Command

Command	"C12"[CR]	
Details	Set Image to Creative Cinema Mode	
Response	Acceptable	[ACK] [CR]
	Unacceptable	"?"[CR]

7.14. Image Pure Cinema Command

Command	"C13"[CR]	
Details	Set Image to Pure Cinema Mode	
Response	Acceptable	[ACK] [CR]
	Unacceptable	"?"[CR]

7.15. Image 1 Command

Command	"C14"[CR]	
Details	Set Image to User Image 1 Mode	
Response	Acceptable	[ACK] [CR]
	Unacceptable	"?"[CR]

7.16. Image 2 Command

Command	"C15"[CR]	
Details	Set Image to User Image 2 Mode	
Response	Acceptable	[ACK] [CR]
	Unacceptable	"?"[CR]

7.17. Image 3 Command

Command	"C16"[CR]	
Details	Set Image to User Image 3 Mode	
Response	Acceptable	[ACK] [CR]
	Unacceptable	"?"[CR]

7.18. Image 4 Command

Command	"C17"[CR]	
Details	Set Image to User Image 4 Mode	
Response	Acceptable	[ACK] [CR]
	Unacceptable	"?"[CR]

7.19. Image Brilliant cinema Command

Command	"C19"[CR]	
Details	Set Image to Brilliant cinema Mode	
Response	Acceptable	[ACK] [CR]
	Unacceptable	"?"[CR]

7.20. Image Dynamic Command

Command	"C1A"[CR]	
Details	Set Image to Dynamic Mode	
Response	Acceptable	[ACK] [CR]
	Unacceptable	"?"[CR]

7.21. Image Natural Command

Command	"C1B"[CR]	
Details	Set Image to Natural Mode	
Response	Acceptable	[ACK] [CR]
	Unacceptable	"?"[CR]

7.22. MENU ON Command

Command	"C1C"[CR]	
Details	Show the On Screen Display Menu	
Response	Acceptable	[ACK] [CR]
	Unacceptable	"?"[CR]

7.23. MENU OFF Command

Command	"C1D"[CR]	
Details	Show the On Screen Display Menu	
Response	Acceptable	[ACK] [CR]
	Unacceptable	"?"[CR]

7.24. DISPLAY CLEAR Command

Command	"C1E"[CR]	
Details	Hide the On Screen Display menu.	
Response	Acceptable	[ACK] [CR]
	Unacceptable	"?"[CR]

7.25. Image x.v. Color Command

Command	"C1F"[CR]	
Details	Set Image to x.v.Color Mode	
Response	Acceptable	[ACK] [CR]
	Unacceptable	"?"[CR]

7.26. Video Source VIDEO Command

Command	"C23"[CR]	
Details	Set Input Source to Video	
Response	Acceptable	[ACK] [CR]
	Unacceptable	"?"[CR]

7.27. Video Source S-VIDEO Command

Command	"C24"[CR]	
Details	Set Input Source to S-Video	
Response	Acceptable	[ACK] [CR]
	Unacceptable	"?"[CR]

7.28. Video Source COMPONENT 1 Command

Command	"C25"[CR]	
Details	Set Input Source to Component 1	
Response	Acceptable	[ACK] [CR]
	Unacceptable	"?"[CR]

7.29. Video Source COMPONENT 2 Command

Command	"C26"[CR]	
Details	Set Input Source to Component 2	
Response	Acceptable	[ACK] [CR]
	Unacceptable	"?"[CR]

7.30. Power Management ON Command

Command	"C2A"[CR]	
Details	Set Power Management to ON The status is stored in EEPROM and its setting lasts regardless of POWER ON/OFF.	
Response	Acceptable	[ACK] [CR]
	Unacceptable	"?"[CR]

7.31. Power Management OFF Command

Command	"C2B"[CR]	
Details	Set Power Management to OFF The status is stored in EEPROM and its setting lasts regardless of POWER ON/OFF.	
Response	Acceptable	[ACK] [CR]
	Unacceptable	"?"[CR]

7.32. Screen Zoom size Command

Command	"C2C"[CR]	
Details	Set Computer / Video screen size to Zoom	
Response	Acceptable	[ACK] [CR]
	Unacceptable	"?"[CR]

7.33. Screen Natural wide size Command

Command	"C2D"[CR]	
Details	Set Computer / Video screen size to Natural wide	
Response	Acceptable	[ACK] [CR]
	Unacceptable	"?"[CR]

7.34. Image 5 Command

Command	"C36"[CR]	
Details	Set Image to User Image 5 Mode	
Response	Acceptable	[ACK] [CR]
	Unacceptable	"?"[CR]

7.35. Image 6 Command

Command	"C37"[CR]	
Details	Set Image to User Image 6 Mode	
Response	Acceptable	[ACK] [CR]
	Unacceptable	"?"[CR]

7.36. Image 7 Command

Command	"C38"[CR]	
Details	Set Image to User Image 7 Mode	
Response	Acceptable	[ACK] [CR]
	Unacceptable	"?"[CR]

7.37. Point Right Command

Command	"C3A"[CR]	
Details	Move Pointer of On Screen Display Menu to the right This command works the same as the right-pointing button (">") of the projector	
Response	Acceptable	[ACK] [CR]
	Unacceptable	"?"[CR]

7.38. Point Left Command

Command	"C3B"[CR]	
Details	Move Pointer of On Screen Display to the left This command works the same as the left-pointing button ("<") of the projector	
Response	Acceptable	[ACK] [CR]
	Unacceptable	"?"[CR]

7.39. Point Up Command

Command	"C3C"[CR]	
Details	Move Up Pointer of On Screen Display This command works the same as the upward pointer of the projector	
Response	Acceptable	[ACK] [CR]
	Unacceptable	"?"[CR]

7.40. Point Down Command

Command	"C3D"[CR]	
Details	Move Down Pointer of On Screen Display This command works the same as the downward pointer of the projector	
Response	Acceptable	[ACK] [CR]
	Unacceptable	"?"[CR]

7.41. ENTER Command

Command	"C3F"[CR]	
Details	This command works the same as "OK" button of the projector and the remote control	
Response	Acceptable	[ACK] [CR]
	Unacceptable	"?"[CR]

7.42. RESET Command

Command	"C40"[CR]	
Details	This command works the same as "RESET" button of the remote control	
Response	Acceptable	[ACK] [CR]
	Unacceptable	"?"[CR]

7.43. BACK Command

Command	"C41"[CR]	
Details	This command works the same as "BACK" button of the remote control	
Response	Acceptable	[ACK] [CR]
	Unacceptable	"?"[CR]

7.44. FREEZE ON Command

Command	"C43"[CR]	
Details	Freeze the screen. This command works the same as "FREEZE" button of the remote control, but it does not operate Freeze OFF.	
Response	Acceptable	[ACK] [CR]
	Unacceptable	"?"[CR]

7.45. FREEZE OFF Command

Command	"C44"[CR]	
Details	Cancel Freeze function. This command works the same as "FREEZE" button of the remote control for Freeze OFF, but does not work for Freeze ON.	
Response	Acceptable	[ACK] [CR]
	Unacceptable	"?"[CR]

7.46. Factory default Command

Command	"C4C"[CR]	
Details	Reset status to Factory default value.	
Response	Acceptable	[ACK] [CR]
	Unacceptable	"?"[CR]

7.47. Computer Source Analog RGB Command

Command	"C50"[CR]	
Details	Set Input Source to Computer (Analog RGB)	
Response	Acceptable	[ACK] [CR]
	Unacceptable	"?"[CR]

7.48. Computer Source Scart Command

Command	"C51"[CR]	
Details	Set Input Source to Computer (Scart) Available only for international models.	
Response	Acceptable	[ACK] [CR]
	Unacceptable	"?"[CR]

7.49. HDMI 1 Command

Command	"C53"[CR]	
Details	Set Input Source to HDMI1	
Response	Acceptable	[ACK] [CR]
	Unacceptable	"?"[CR]

7.50. HDMI 2 Command

Command	"C54"[CR]	
Details	Set Input Source to HDMI2	
Response	Acceptable	[ACK] [CR]
	Unacceptable	"?"[CR]

7.51. Screen Anamorphic size Command

Command	"C69"[CR]	
Details	Set Computer / Video screen size to Anamorphic	
Response	Acceptable	[ACK] [CR]
	Unacceptable	"?"[CR]

7.52. Lamp mode AUTO 1 Command

Command	"C72" [CR]	
Details	Set Lamp Mode to Auto 1 Mode	
Response	Acceptable	[ACK] [CR]
	Unacceptable	"?"(CR)

7.53. Lamp mode AUTO 2 Command

Command	"C73" [CR]	
Details	Set Lamp Mode to Auto 2 Mode	
Response	Acceptable	[ACK] [CR]
	Unacceptable	"?"(CR)

7.54. Lamp mode NORMAL Command

Command	"C74" [CR]	
Details	Set Lamp Mode to Normal	
Response	Acceptable	[ACK] [CR]
	Unacceptable	" ? "(CR)

7.55. Lamp mode ECO Command

Command	"C75" [CR]	
Details	Set Lamp Mode to Eco	
Response	Acceptable	[ACK] [CR]
	Unacceptable	"?"[CR]

7.56. Ceiling ON Command

Command	"C76"[CR]	
Details	Set screen setting to Ceiling ON	
Response	Acceptable	[ACK] [CR]
	Unacceptable	"?"[CR]

7.57. Ceiling OFF Command

Command	"C77"[CR]	
Details	Set screen setting to Ceiling OFF	
Response	Acceptable	[ACK] [CR]
	Unacceptable	"?"[CR]

7.58. Rear ON Command

Command	"C78"(CR)	
Details	Set screen setting to Rear ON	
Response	Acceptable	[ACK] [CR]
	Unacceptable	"?"(CR)

7.59. Rear OFF Command

Command	"C79"(CR)	
Details	Set screen setting to Rear OFF	
Response	Acceptable	[ACK] [CR]
	Unacceptable	"?"(CR)

7.60. Logo OFF Command

Command	"C7A"(CR)	
Details	Set Logo to OFF	
Response	Acceptable	[ACK] [CR]
	Unacceptable	"?"[CR]

7.61. Logo Default Command

Command	"C7B"[CR]	
Details	Set Logo to Default	
Response	Acceptable	[ACK] [CR]
	Unacceptable	"?"[CR]

7.62. Logo User Command

Command	"C7C"[CR]	
Details	Set Logo to User Although projector returns ACK, the command is not executed when no image is captured.	
Response	Acceptable	[ACK] [CR]
	Unacceptable	"?"[CR]

7.63. Logo Capture Command

Command	"C7D"[CR]	
Details	Capture current image as Logo image	
Response	Acceptable	[ACK] [CR]
	Unacceptable	"?"[CR]

7.64. My Picture ON Command

Command	"C7E"[CR]	
Details	Change Logo image into the captured image. However, this command cannot release the captured image from Logo.	
Response	Acceptable	[ACK] [CR]
	Unacceptable	"?"[CR]

7.65. My Picture OFF Command

Command	"C7F"[CR]	
Details	Release the displaying captured image from Logo This command is not to stop displaying Logo shown in the Opening Count down.	
Response	Acceptable	[ACK] [CR]
	Unacceptable	"?"[CR]

7.66. AUTO PC Adjust Command

Command	"C89"[CR]	
Details	Execute Auto PC Adj. operation This command works the same as "Auto Adj." of Menu. When this command is sent during Auto PC Adj. operation, the operation is suspended.	
Response	Acceptable	[ACK] [CR]
	Unacceptable	"?"[CR]

8. Status Read Command

8.1.Format

8.1.1. PC issue commands in format as below.

“CR”Command [CR]

Command: 1 character (See Status Read Command Table)

8.1.2. When a projector receives the appropriate command, it returns a character line as the required data.

Required Data [CR]

Required data: A character line (See Status Read Command Table)

8.1.3. When the received data cannot be decoded, the projector returns “?”[CR]

8.2.Transfer Example

Get input mode for projector by basic command

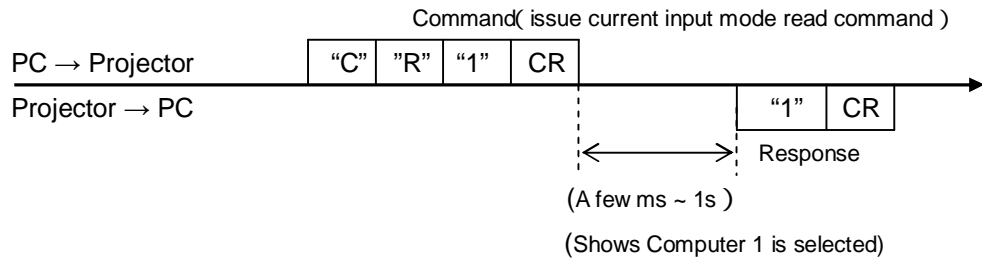

8.3.Status Read Command

Command	“CR0”[CR]	
Details	Get the projector status	
Response	Acceptable	“%1”[CR]
	%1	“00” = Power ON “80” = Standby (Normal Standby) Impossible to respond during Super Standby “40” = Processing Countdown “20” = Processing Cooling down “10” = Power Failure “28” = Processing cooling down due to abnormal temperature “88” = Standby after cooling down due to abnormal temperature Standby due to door failure “24” = Processing Power Save / Cooling down “04” = Power Save “21” = Processing Cooling down after OFF due to lamp failure “81” = Standby after Cooling down due to lamp failure
	Unacceptable	“?”[CR]

【 Details for Response 】

“00”[CR]

Status: Power ON
Normal image is on-screen.

“80”[CR]

Status: Standby
(Z3000: This status cannot be detected when projector is in Super standby mode, but in Normal Standby mode)
When the status is normal Standby, Status Read Commands are always available, but Functional Execution Commands are not available except Power ON Command.

“40”[CR]

Status: Processing Countdown
When “Display” in Setting menu is ON and POWER ON is executed, it starts processing Countdown.
When “Display” in Setting menu is OFF, Countdown is canceled and the status moves to Quick Power ON.

“20”[CR]

Status: Processing Cooling down
When the status is Power ON and Power OFF Command (“C01”[CR], “C02”[CR]) is executed, it moves to Cooling down. This status automatically moves to Standby when lamp is turned off and the fan spin finishes after 60 seconds. The fan spin time depends on models.
This function is used to cool down lamps and other optical parts, and is quite important to projector’s reliability. During this time, Control Commands are invalid.

“10”[CR]

Status: Power Failure
When the power supply voltage inside the projector reaches abnormal status, the projector is automatically turned off. The projector returns “10”[CR], which shows it moves to Power OFF status due to power failure.

“28”[CR]

Status: Processing cooling down due to abnormal temperature
When the inside temperature becomes abnormally high, it automatically starts Cooling down. Response for this status is “28”[CR].
Even if the temperature decreases during this process, Cooling down is executed.

“88”[CR]

Status: Standby after Cooling Down due to abnormal temperature
The projector status is restored from abnormal temperature.
When the status moves to Standby after Cooling Down due to abnormal temperature, it returns “88”[CR].
This shows the status turns to Standby because of abnormal temperature and door

failure.

This status maintains until next operation is done, When Power On is executed, the information of abnormal temperature is canceled and normal operation is executed.

“24”[CR]

Status: Processing Power Save / Cooling Down

When Power Management function in the Setting menu works and no signal is received for 5 minutes, lamps are turned off and the status goes to Power Save / Cooling Down.

(During this time, the green LED of the projector is off)

During this time, Functional Execution Commands are invalid. (Not executed)

The status moves to Power Save at set hours after the operation of Cooling Down.

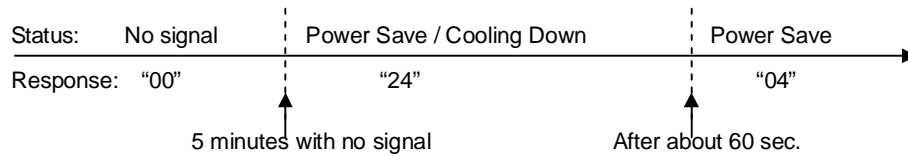

“04”[CR]

Status: Power Save

This shows it moves to Power Save status by Power management function in the Setting menu

“21”[CR]

Status: Processing Cooling Down after OFF due to lamp failure

When a projector is turned off because of lamp failure, it starts Cooling Down automatically. It returns “21”[CR].

The response command “21”[CR] maintains during Cooling Down.

“81”[CR]

Status: Standby after Cooling Down due to lamp failure

When the status moves to Standby after Cooling Down due to lamp failure, it returns “81” [CR]. This shows the status turns to Standby because of lamp failure. This status stays until next operation is executed.

When Power ON is executed, the information of lamp failure is canceled and normal operation is executed.

8.4. Input Mode Read Command

Command	"CR1"[CR]	
Details	Get the selected Input source. Projector returns selected source in Z3000.	
Response	Acceptable	"%1"[CR]
	%1	"0" = Video is selected "1" = S-Video is selected "2" = Component1 is selected "3" = Component2 is selected "4" = HDMI1 is selected "5" = HDMI2 is selected "6" = omputer(Analog) is selected "7" = Computer(Scart) is selected
	Unacceptable	"?"[CR]

8.5. Lamp Time Read Command

Command	"CR3"[CR]	
Details	Get the total lamp running time	
Response	Acceptable	"%1"[CR]
	%1	5-digit character shows the time. Example: "00410"[CR] = 410Hours
	Unacceptable	"?"[CR]

8.6. Setting Read Command

Command	"CR4"[CR]	
Details	Get the screen setting status such as Ceiling / Rear	
Response	Acceptable	"%1"[CR]
	%1	"11"[CR] = Normal Screen Setting "10"[CR] = Picture is top/bottom reversed (Status : Ceiling & Rear On) "01"[CR] = Picture is left/right reversed (Status : Rear) "00"[CR] = Picture is top/bottom and left/right reversed (Status : Ceiling ON)
	Unacceptable	"?"[CR]

8.7.Temp Read Command

Command	"CR6"[CR]	
Details	Get the temperature data inside the projector. It is possible to get all the temperature at once when several temperature sensors are installed to the projector,	
Response	Acceptable	"%1_%2_%3"[CR]
	%1 %2 %3	<p>%1 = Temperature of Sensor 1 %2 = Temperature of Sensor 2 %3 = Temperature of Sensor 3</p> <p>Temperature data is shown as "00.0" When the temperature plunges to sub-zero, the first character becomes ".", such as "-05.5"[CR] When the projector cannot return temperature data due to hardware problems, the first character becomes "E" like "E00.0"[CR]</p> <p>When the status is Standby or in 10 seconds after Power On, temperature may approach the abnormal status due to ballast lamp's residual heat. Therefore the projector does not process particular operation for abnormal temperature under situations above. In those situations, the temperature data are shown as "□----". When some temperature sensors are installed, the projector sends commands continuously.</p> <p>"□31.5 □□35.2 □□32.8"[CR]</p> <p>First number indicates the data of sensor 1, followed by single space, and the data of sensor 2 and 3 continues.</p>
	Unacceptable	"?"[CR]