

# **BASIC SERIAL COMMAND SPECIFICATIONS**

PLC-XW65

Ver. 1.00

**SANYO Electric Co., Ltd**  
**DS Company**  
**Projector Division**

## — CONTENTS —

1. Overview.....	4
2. Serial Interface Specifications.....	4
2.1. Transfer Specifications .....	4
2.2. Connection.....	4
3. Notes for Communication.....	5
4. Functional Execution Command Table.....	6
5. Status Read Command Table .....	7
6. Functional Execution Command.....	8
6.1. Format .....	8
6.2. Command Pipelining.....	8
6.3. Transfer Example.....	8
6.4. Operation Requirements.....	9
6.5. POWER ON Command .....	10
6.6. POWER OFF Command (Quick Power OFF) .....	10
6.7. POWER OFF Command .....	10
6.8. Computer 1 Command .....	10
6.9. Computer 2 Command .....	10
6.10. Video Command.....	11
6.11. VOLUME + Command .....	11
6.12. VOLUME – Command .....	11
6.13. AUDIO MUTE ON Command .....	11
6.14. AUDIO MUTE OFF Command.....	11
6.15. VIDEO MUTE ON Command.....	12
6.16. VIDEO MUTE OFF Command .....	12
6.17. Screen Normal size Command .....	12
6.18. Screen Wide size Command .....	12
6.19. Image Standard Command.....	12
6.20. Image Real Command .....	12
6.21. Image Cinema Command .....	13
6.22. Image 1 Command.....	13
6.23. Image 2 Command.....	13
6.24. Image 3 Command.....	13
6.25. Image 4 Command.....	13
6.26. Image Blackboard (Green) Command.....	13
6.27. Image Dynamic Command .....	13
6.28. MENU ON Command .....	14
6.29. MENU OFF Command.....	14
6.30. DISPLAY CLEAR Command.....	14
6.31. BRIGHTNESS + Command.....	14

6.32.	<b>BRIGHTNESS – Command</b> .....	14
6.33.	<b>IMAGE (Toggle) Command</b> .....	14
6.34.	<b>ON START Setting Command</b> .....	15
6.35.	<b>ON START Cancel Command</b> .....	15
6.36.	<b>Power Management Ready Command</b> .....	15
6.37.	<b>Power Management OFF Command</b> .....	15
6.38.	<b>Power Management Shut down Command</b> .....	15
6.39.	<b>D.ZOOM + Command</b> .....	15
6.40.	<b>D.ZOOM – Command</b> .....	16
6.41.	<b>Computer 1 S-Video Command</b> .....	16
6.42.	<b>Image Colorboard Command</b> .....	16
6.43.	<b>POINTER RIGHT Command</b> .....	16
6.44.	<b>POINTER LEFT Command</b> .....	16
6.45.	<b>POINTER UP Command</b> .....	16
6.46.	<b>POINTER DOWN Command</b> .....	17
6.47.	<b>ENTER Command</b> .....	17
6.48.	<b>FREEZE ON Command</b> .....	17
6.49.	<b>FREEZE OFF Command</b> .....	17
6.50.	<b>COMPUTER INPUT 1 Analog RGB Command</b> .....	17
6.51.	<b>COMPUTER INPUT 1 Scart Command</b> .....	17
6.52.	<b>COMPUTER 1 Component Command</b> .....	18
6.53.	<b>AUTO PC ADJ. Command</b> .....	18
6.54.	<b>PRESENTATION TIMER Command</b> .....	18
6.55.	<b>KEYSTONE ↑Command</b> .....	18
6.56.	<b>KEYSTONE ↓Command</b> .....	18
7.	<b>Status Read Command</b> .....	19
7.1.	<b>Format</b> .....	19
7.2.	<b>Transfer Example</b> .....	19
7.3.	<b>Status Read Command</b> .....	19
7.4.	<b>Input Mode Read Command</b> .....	22
7.5.	<b>Lamp Time Read Command</b> .....	22
7.6.	<b>Setting Read Command</b> .....	22
7.7.	<b>Temp Read Command</b> .....	22
7.8.	<b>Lamp Mode Read Command</b> .....	23

## 1. Overview

- 1.1. These specifications define projector control commands for PLC-XW65.
- 1.2. The projector control commands are used to remotely control a projector through RS-232C from a computer.

## 2. Serial Interface Specifications

### 2.1. Transfer Specifications

Item	Specifications
Synchronous system	Asynchronous
Transmission Speed	9600 / 19200
Data Length	8 bit
Parity	N/A
Stop Bit	1
Flow Control	N/A

- 1) Transmission speed: initial setting value is 19200.
- 2) Transmission speed can be changed in service mode.

### 2.2. Connection

Dedicated serial cable must be used for connection to a computer and a projector.

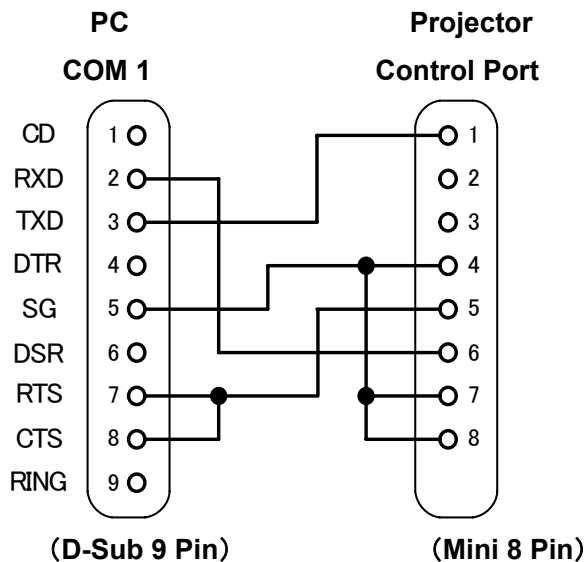

### 3. Notes for Communication

**3.1.** The projector control command is defined as one command/one line that starts with “C” and ends with carriage return (0x0D).

**3.2.** There are two types of Commands: Functional Execution Commands and Status Read Commands.

Example of Functional Execution Command: “C05” [CR]

Example of Status Read Command: “CR0” [CR]

**3.3.** When it takes more than one second to receive one command, it does not operate.

It clears the information of buffer when the projector receives LF (0x0A) or EOF (0x1A) and takes more than one second to receive one command.

**3.4.** For Command pipelining, wait for the interval of 100ms after receiving a Command.

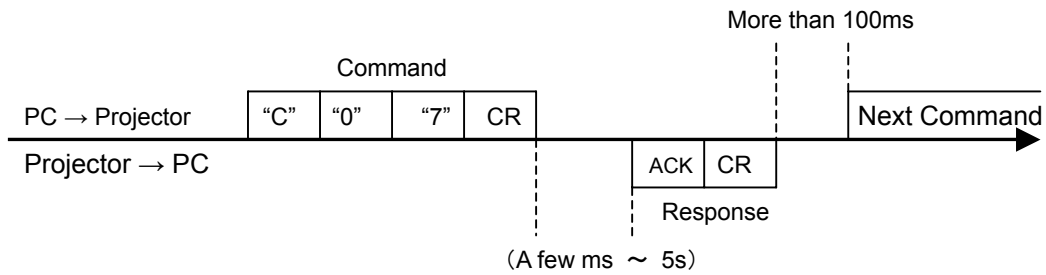

**3.4.1.** When a command is issued before receiving a response, the function is not executed properly.

**3.4.2.** Except for when there is no Response for more than 5 seconds.

**3.5.** It takes about 5 seconds for internal initialization after plugging in AC power. During this time, it cannot process commands. Do not issue any command.

**3.6.** The number of characters of response to Status Read Commands depends on commands.

Please see [7. Status Read Commands].

**3.7.** Characters for commands must be Capital (A - Z).

#### 4. Functional Execution Command Table

Command	Item	Command	Item
C00	POWER ON	C20	BRIGHTNESS +
C01	POWER OFF (Quick Power OFF)	C21	BRIGHTNESS -
C02	POWER OFF	C22	-----
C03	-----	C23	-----
C04	-----	C24	-----
C05	Computer 1	C25	-----
C06	Computer 2	C26	-----
C07	Video	C27	IMAGE (Toggle)
C08	-----	C28	ON START Enable
C09	VOLUME +	C29	ON START Disable
C0A	VOLUME -	C2A	Power Management Ready
C0B	AUDIO MUTE ON	C2B	Power Management OFF
C0C	AUDIO MUTE OFF	C2C	-----
C0D	VIDEO MUTE ON	C2D	-----
C0E	VIDEO MUTE OFF	C2E	Power Management Shut down
C0F	Screen Normal size (4 : 3)	C2F	-----
C10	Screen Wide size (16 : 9)	C30	D.ZOOM +
C11	Image Standard	C31	D.ZOOM -
C12	Image Real	C32	-----
C13	Image Cinema	C33	-----
C14	Image 1	C34	Computer 1 S-video
C15	Image 2	C35	-----
C16	Image 3	C36	-----
C17	Image 4	C37	-----
C18	Image Blackboard	C38	-----
C19	Image Dynamic	C39	Image Colorboard
C1A	-----	C3A	POINTER RIGHT
C1B	-----	C3B	POINTER LEFT
C1C	MENU ON	C3C	POINTER UP
C1D	MENU OFF	C3D	POINTER DOWN
C1E	DISPLAY CLEAR	C3E	-----
C1F	-----	C3F	ENTER

----- means no function.

Command	Item	Command	Item
C43	FREEZE ON	C83	-----
C44	FREEZE OFF	C84	-----
C45	-----	C85	-----
C46	-----	C86	-----
C47	-----	C87	-----
C48	-----	C88	-----
C49	-----	C89	Auto PC ADJ.
C4A	-----	C8A	PRESENTATION TIMER
C4B	-----	C8B	-----
C4C	-----	C8C	-----
C4D	-----	C8D	-----
C4E	-----	C8E	KEYSTONE ↑
C4F	-----	C8F	KEYSTONE ↓
C50	Computer 1 Analog RGB	C90	-----
C51	Computer 1 Scart	C91	-----
C52	-----	C92	-----
C53	-----	C93	-----
C54	Computer 1 Component	C94	-----

----- means no function.

### 5. Status Read Command Table

Command	Item	Memo
CR0	Status Read	
CR1	Input Mode Read	
CR2	-----	
CR3	(Corresponding) Lamp Time Read	
CR4	Setting Read	
CR5	-----	
CR6	Temp Read	
CR7	Lamp Mode Read	

----- means no function.

## 6. Functional Execution Command

### 6.1. Format

6.1.1. PC issues a command in format as below.

“C” **COMMAND** [CR]

Command: two characters (See Basic Functional Execution Command Table)

6.1.2. A projector changes received data to decode and returns a result after being ready to receive next command.

[ACK] [CR] : (0x06、0x0D) When received Functional Execution Commands.

6.1.3. “?” [CR] : When the received data cannot be decoded.

### 6.2. Command Pipelining

When some functions need the command pipelining, the performance is the same as that of the remote control;

6.2.1. System: issue any command every 100 ms.

6.2.2. When receiving the appropriate command, the function is executed for 120 ms from the moment.

6.2.3. When receiving the same command continuously within 120 ms, the function is executed for another 120 ms from the moment.

6.2.4. When there is no incoming command after 120 ms, the execution of pipelining is stopped.

6.2.5. When the projector receives other incoming commands within 120ms, the execution of pipelining is stopped.

### 6.3. Transfer Example

Switch the projector to video mode with Basic Command.

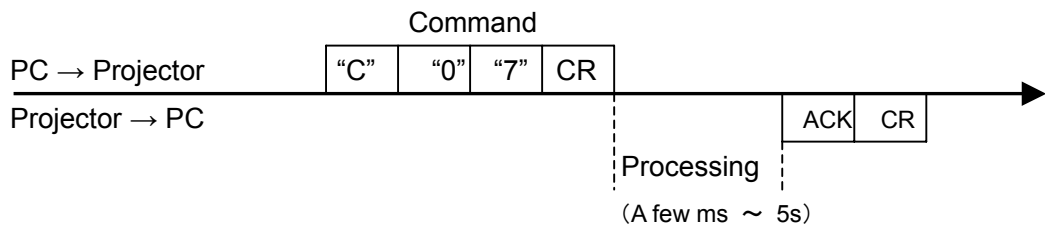

#### 6.4. Operation Requirements

When the projector's status is any of below, Functional Execution Commands are limited.

Projector Status	Available Functional Execution Commands
Standby Mode	C00 : POWER ON
Processing Countdown	C00 : POWER ON → Countdown is terminated C01 : POWER OFF C02 : POWER OFF → Countdown is terminated
Processing Cooling Down	NONE
Cooling Down due to Abnormal Temperature	NONE
Abnormal Temperature Status	NONE
Processing Power Save / Cooling Down	NONE
Power Save Status	C00 : POWER ON C01 : POWER OFF
Input search : On1 / On2	Although projector receives Input source commands, Input search does no start.

Note) When the status is as above, even if the projector receives other commands,

it returns **[ACK] [CR]**.

**6.5. POWER ON Command**

Command	"C00" [CR]	
Detail	Power ON When already Power is ON, nothing is done. When sending this command during processing Countdown, Countdown terminates.	
Response	Acceptable	[ACK] [CR]
	Unacceptable	"?"[CR]

**6.6. POWER OFF Command (Quick Power OFF)**

Command	"C01" [CR]	
Detail	Power OFF (Standby) When Power is OFF with ON/STAND-BY button of the remote control, "Power OFF?" is displayed. However, as soon as this command is sent, Quick Power OFF is executed.	
Response	Acceptable	[ACK] [CR]
	Unacceptable	"?"[CR]

**6.7. POWER OFF Command**

Command	"C02" [CR]	
Detail	Power OFF (Standby). The command operates the same Power OFF function as ON/STAND-BY button of the projector and remote control. Once this command is sent, "Power OFF?" is displayed. If this command is sent again while it is displayed, Power OFF is executed. When sending this command during Countdown, Countdown is terminated.	
Response	Acceptable	[ACK] [CR]
	Unacceptable	"?"[CR]

**6.8. Computer 1 Command**

Command	"C05" [CR]	
Detail	Select Computer 1 Input Note) Although Input search setting is On1/On2, projector does not execute Input search by receiving this command.	
Response	Acceptable	[ACK] [CR]
	Unacceptable	"?"[CR]

**6.9. Computer 2 Command**

Command	"C06" [CR]	
Detail	Select Computer 2 Input Note) Although Input search setting is On1/On2, projector does not execute Input search by receiving this command.	
Response	Acceptable	[ACK] [CR]
	Unacceptable	"?"[CR]

**6.10. Video Command**

Command	"C07" [CR]	
Detail	Select Video Input Note) Although Input search setting is On1/On2, projector does not execute Input search by receiving this command.	
Response	Acceptable	[ACK] [CR]
	Unacceptable	" ? "[CR]

**6.11. VOLUME + Command**

Command	"C09" [CR]	
Detail	Volume Up. This command operates the same VOLUME UP function as a projector and a remote control.	
Response	Acceptable	[ACK] [CR]
	Unacceptable	" ? "[CR]

**6.12. VOLUME – Command**

Command	"C0A" [CR]	
Detail	Volume Down This command operates the same VOLUME DOWN function as the projector and a remote control.	
Response	Acceptable	[ACK] [CR]
	Unacceptable	" ? "[CR]

**6.13. AUDIO MUTE ON Command**

Command	"C0B" [CR]	
Detail	Sound Mute ON. This command works the same as "MUTE" button of a remote control for Mute ON, but does not work for Mute OFF.	
Response	Acceptable	[ACK] [CR]
	Unacceptable	" ? "[CR]

**6.14. AUDIO MUTE OFF Command**

Command	"C0C" [CR]	
Detail	Sound Mute OFF. This command works the same as "MUTE" button of a remote control for Mute OFF, but does not work for Mute ON.	
Response	Acceptable	[ACK] [CR]
	Unacceptable	" ? "[CR]

**6.15. VIDEO MUTE ON Command**

Command	"C0D"[CR]	
Detail	Video Mute ON. This command works the same as "NO SHOW" button of a remote control a No Show ON, but does not work for No Show OFF.	
Response	Acceptable	[ACK] [CR]
	Unacceptable	"?"[CR]

**6.16. VIDEO MUTE OFF Command**

Command	"C0E" [CR]	
Detail	Video Mute OFF. This command works the same as "NO SHOW" button of a remote control for No Show OFF, but does not work for No Show ON.	
Response	Acceptable	[ACK] [CR]
	Unacceptable	"?"[CR]

**6.17. Screen Normal size Command**

Command	"C0F" [CR]	
Detail	Set screen size to Normal (4:3).	
Response	Acceptable	[ACK] [CR]
	Unacceptable	"?"[CR]

**6.18. Screen Wide size Command**

Command	"C10" [CR]	
Detail	Set screen size to Wide (16:9).	
Response	Acceptable	[ACK] [CR]
	Unacceptable	"?"[CR]

**6.19. Image Standard Command**

Command	"C11" [CR]	
Detail	Set image to Standard mode.	
Response	Acceptable	[ACK] [CR]
	Unacceptable	"?"[CR]

**6.20. Image Real Command**

Command	"C12" [CR]	
Detail	Set image to Real mode.	
Response	Acceptable	[ACK] [CR]
	Unacceptable	"?"[CR]

**6.21. Image Cinema Command**

Command	"C13" [CR]	
Detail	Set image to Cinema mode.	
Response	Acceptable	[ACK] [CR]
	Unacceptable	"?"[CR]

**6.22. Image 1 Command**

Command	"C14" [CR]	
Detail	Set image to Image 1 mode.	
Response	Acceptable	[ACK] [CR]
	Unacceptable	"?"[CR]

**6.23. Image 2 Command**

Command	"C15" [CR]	
Detail	Set image to Image 2 mode.	
Response	Acceptable	[ACK] [CR]
	Unacceptable	"?"[CR]

**6.24. Image 3 Command**

Command	"C16" [CR]	
Detail	Set image to Image 3 mode.	
Response	Acceptable	[ACK] [CR]
	Unacceptable	"?"[CR]

**6.25. Image 4 Command**

Command	"C17" [CR]	
Detail	Set image to Image 4 mode.	
Response	Acceptable	[ACK] [CR]
	Unacceptable	"?"[CR]

**6.26. Image Blackboard (Green) Command**

Command	"C18" [CR]	
Detail	Set image to Blackboard (Green) mode.	
Response	Acceptable	[ACK] [CR]
	Unacceptable	"?"[CR]

**6.27. Image Dynamic Command**

Command	"C19" [CR]	
Detail	Set image to Dynamic mode.	
Response	Acceptable	[ACK] [CR]
	Unacceptable	"?"[CR]

**6.28. MENU ON Command**

Command	"C1C" [CR]	
Detail	Display Menu of On Screen Display.	
Response	Acceptable	[ACK] [CR]
	Unacceptable	"?"[CR]

**6.29. MENU OFF Command**

Command	"C1D" [CR]	
Detail	Clear Menu of On Screen Display.	
Response	Acceptable	[ACK] [CR]
	Unacceptable	"?"[CR]

**6.30. DISPLAY CLEAR Command**

Command	"C1E" [CR]	
Detail	Clear On Screen Display. Clear On Screen Display unconditionally.	
Response	Acceptable	[ACK] [CR]
	Unacceptable	"?"[CR]

**6.31. BRIGHTNESS + Command**

Command	"C20" [CR]	
Detail	Brightness of User Control +1.	
Response	Acceptable	[ACK] [CR]
	Unacceptable	"?"[CR]

**6.32. BRIGHTNESS – Command**

Command	"C21" [CR]	
Detail	Brightness of User Control –1.	
Response	Acceptable	[ACK] [CR]
	Unacceptable	"?"[CR]

**6.33. IMAGE (Toggle) Command**

Command	"C27"[CR]	
Detail	Switch Image Setting status. This command works the same as "IMAGE" button on a remote control.	
Response	Acceptable	[ACK] [CR]
	Unacceptable	"?"[CR]

**6.34. ON START Setting Command**

Command	"C28" [CR]	
Detail	Set Power ON Start. This status is stored in EEPROM and retained regardless of Power OFF/ON.	
Response	Acceptable	[ACK] [CR]
	Unacceptable	" ? "[CR]

**6.35. ON START Cancel Command**

Command	"C29" [CR]	
Detail	Cancel Power ON Start. This status is stored in EEPROM and retained regardless of Power OFF/ON.	
Response	Acceptable	[ACK] [CR]
	Unacceptable	" ? "[CR]

**6.36. Power Management Ready Command**

Command	"C2A" [CR]	
Detail	Set Power Management to Ready mode. This status is stored in EEPROM and retained regardless of Power ON/OFF.	
Response	Acceptable	[ACK] [CR]
	Unacceptable	" ? "[CR]

**6.37. Power Management OFF Command**

Command	"C2B" [CR]	
Detail	Set Power Management OFF. This status is stored in EEPROM and retained regardless of Power ON/OFF.	
Response	Acceptable	[ACK] [CR]
	Unacceptable	" ? "[CR]

**6.38. Power Management Shut down Command**

Command	"C2E" [CR]	
Detail	Set Power Management to Shut down mode. This status is stored in EEPROM and retained regardless of Power OFF/ON.	
Response	Acceptable	[ACK] [CR]
	Unacceptable	" ? "[CR]

**6.39. D.ZOOM + Command**

Command	"C30" [CR]	
Detail	Make screen image larger. This command works the same as "D.ZOOM ▲" button of the remote control.	
Response	Acceptable	[ACK] [CR]
	Unacceptable	" ? "[CR]

**6.40. D.ZOOM – Command**

Command	"C31" [CR]	
Detail	Make screen image smaller. This command works the same as "D.ZOOM ▼" button of the remote control.	
Response	Acceptable	[ACK] [CR]
	Unacceptable	" ? "[CR]

**6.41. Computer 1 S-Video Command**

Command	"C34" [CR]	
Detail	Select S-video of Computer 1 input. Note) Although Input search setting is On1/On2, projector does not execute Input search by receiving this command.	
Response	Acceptable	[ACK] [CR]
	Unacceptable	" ? "[CR]

**6.42. Image Colorboard Command**

Command	"C39" [CR]	
Detail	Set Image to Color board mode.	
Response	Acceptable	[ACK] [CR]
	Unacceptable	" ? "[CR]

**6.43. POINTER RIGHT Command**

Command	"C3A" [CR]	
Detail	Move the Pointer of Menu on screen display to the right. This command differs from the operation of pointer ">" of a remote control and has no function of Zoom +.	
Response	Acceptable	[ACK] [CR]
	Unacceptable	" ? "[CR]

**6.44. POINTER LEFT Command**

Command	"C3B" [CR]	
Detail	Move the Pointer of Menu on screen display to the left. This command differs from the operation of pointer "<" of a remote control and has no function of Zoom -.	
Response	Acceptable	[ACK] [CR]
	Unacceptable	" ? "[CR]

**6.45. POINTER UP Command**

Command	"C3C" [CR]	
Detail	Move up the Pointer of Menu on screen display. This command differs from a pointer "↑" of a remote control and does not execute Keystone +.	
Response	Acceptable	[ACK] [CR]
	Unacceptable	" ? "[CR]

#### 6.46. POINTER DOWN Command

Command	"C3D" [CR]	
Detail	Move down the Pointer of Menu on screen display. This command differs from a pointer "↓" of a remote control and does not execute Keystone -.	
Response	Acceptable	[ACK] [CR]
	Unacceptable	"?"[CR]

#### 6.47. ENTER Command

Command	"C3F" [CR]	
Detail	This command works the same as "SELECT" button of a remote control.	
Response	Acceptable	[ACK] [CR]
	Unacceptable	"?"[CR]

#### 6.48. FREEZE ON Command

Command	"C43" [CR]	
Detail	Freeze the screen. This command works the same as "FREEZE" button of the remote control for Freeze ON, but does not work for Freeze OFF.	
Response	Acceptable	[ACK] [CR]
	Unacceptable	"?"[CR]

#### 6.49. FREEZE OFF Command

Command	"C44" [CR]	
Detail	Cancel Freeze function. This command works the same as "FREEZE" button of the remote control for Freeze OFF, but does not work for Freeze ON.	
Response	Acceptable	[ACK] [CR]
	Unacceptable	"?"[CR]

#### 6.50. COMPUTER INPUT 1 Analog RGB Command

Command	"C50" [CR]	
Detail	Select Analog RGB connection for Computer 1 input. Note) Although Input search setting is On1/On2, projector does not execute Input search by receiving this command.	
Response	Acceptable	[ACK] [CR]
	Unacceptable	"?"[CR]

#### 6.51. COMPUTER INPUT 1 Scart Command

Command	"C51" [CR]	
Detail	Select Scart connection for Computer 1 input. Note) Although Input search setting is On1/On2, projector does not execute Input search by receiving this command.	
Response	Acceptable	[ACK] [CR]
	Unacceptable	"?"[CR]

### 6.52. COMPUTER 1 Component Command

Command	"C54" [CR]	
Detail	Select Component connection for Computer 1 input. Note) Although Input search setting is On1/On2, projector does not execute Input search by receiving this command.	
Response	Acceptable	[ACK] [CR]
	Unacceptable	"?"[CR]

### 6.53. AUTO PC ADJ. Command

Command	"C89" [CR]	
Detail	Execute Auto PC Adj. This command works the same as AUTO PC. button of the remote control. Sending the command during operation, Auto PC Adj. is suspended.	
Response	Acceptable	[ACK] [CR]
	Unacceptable	"?"[CR]

### 6.54. PRESENTATION TIMER Command

Command	"C8A" [CR]	
Detail	Execute Presentation Timer. This command works the same as "P-TIMER" button of the remote control.	
Response	Acceptable	[ACK] [CR]
	Unacceptable	"?"[CR]

### 6.55. KEYSTONE ↑ Command

Command	"C8E" [CR]	
Detail	Correct keystone distortion by reducing upper part of image.	
Response	Acceptable	[ACK] [CR]
	Unacceptable	"?"[CR]

### 6.56. KEYSTONE ↓ Command

Command	"C8F" [CR]	
Detail	Correct keystone distortion by reducing down part of image.	
Response	Acceptable	[ACK] [CR]
	Unacceptable	"?"[CR]

## 7. Status Read Command

### 7.1. Format

7.1.1. PC issues commands in format as below;

**"CR" Command [CR]**

Command : 1 character (See Basic Status Read Command Table)

7.1.2. When a projector receives the appropriate command, it returns a character line as the required data.

**Required Data [CR]**

Required Data : A character line (See Basic Status Read Command Table)

7.1.3. When the received data cannot be decoded, the projector returns "?" [CR].

### 7.2. Transfer Example

Get input mode for projector with basic commands

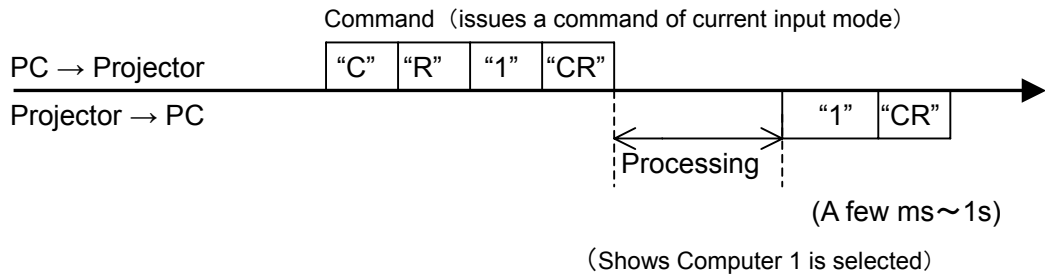

### 7.3. Status Read Command

Command	"CR0" [CR]	
Detail	Get the projector status	
Response	Acceptable	"%1" [CR]
	%1	"00" = Power ON "80" = Standby "40" = Processing Countdown "20" = Processing Cooling Down "10" = Power Failure "28" = Processing Cooling Down due to Temperature Anomaly "88" = Coming back after Temperature Anomaly "24" = Processing Power Save/Cooling Down "04" = Power Save "21" = Cooling Down is in process after Power off due to lamp failure "81" = Standby after Cooling Down due to lamp failure
	Unacceptable	"?" [CR]

#### [Details of Response]

##### "00" [CR]

Status: Power ON

Normal image is on the screen.

### **“80” [CR]**

Status: Standby

When the status is Standby, Status Read Commands are always acceptable, but Functional Execution Commands are not acceptable except POWER ON Command.

**\* Since this model has the Power-saving function, projector does not return this response when Standby mode setting is “Eco”.**

### **“40” [CR]**

Status: Processing Countdown

When “Display” in Setting Menu is ON and POWER ON is executed, it starts processing Countdown.

When “Display” in Setting Menu is OFF, processing Countdown is canceled and the status quickly moves to Power ON.

### **“20” [CR]**

Status: Processing Cooling Down

When the status is Power ON, and POWER OFF Command (“C01” [CR]) is executed, it moves to Cooling Down status.

This status automatically moves to Standby after lamp turns off and the fan spin finishes after about 90 seconds. The fan spin time depends on a model.

This function is used to cool down the lamps and other optical parts and is quite important for projector’s reliability.

During this time, Functional Execution Commands are invalid.

### **“10” [CR]**

Status: Power Failure

When the power supply voltage inside the projector reaches abnormal status, the projector is automatically turned off. The projector returns “10” [CR], which shows it moves to Power OFF status due to power failure. Fan also stops unlike Cooling Down status.

### **“28” [CR]**

Status: Processing Cooling Down due to Temperature Anomaly

When the inside temperature is out of the operating temperature, it automatically starts Cooling Down. Response for this status is “28” [CR].

Even if the temperature decreases during this process, Cooling Down is executed.

### **“88” [CR]**

Status: Coming back after temperature anomaly

When the status moves to Standby after Cooling Down due to temperature anomaly, it

returns "88" [CR].

This shows that the status turns to Standby because of abnormal temperature.

This status maintains until next operation is done. When Power On is executed, the information of temperature anomaly is canceled and normal operation is executed.

### "24" [CR]

Status: Processing Power Save / Cooling Down

Power management function in Setting menu works and the status goes to Power Save / Cooling Down.

During this time, Functional Execution Commands are invalid (not executed).

This status moves to Power Save at set hours after the operation of Cooling Down.

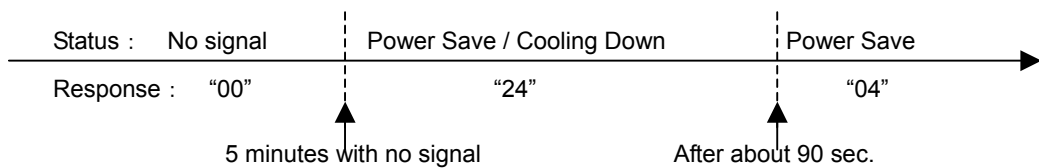

### "04" [CR]

Status: Power Save

This shows that it moves to Power Save status by Power management function in setting menu.

### "21" [CR]

Status: Cooling Down in process after turned off due to lamp failure

When a projector is turned off because of lamp failure, it automatically starts Cooling Down operation, in which the projector returns "21" [CR].

### "81" [CR]

Status: Standby after Cooling Down due to lamp failure

This value is returned when Cooling Down operation due to lamp failure has been completed and the status has been moved to Standby. The status is kept until the next operation starts.

#### 7.4. Input Mode Read Command

Command	"CR1" [CR]	
Detail	Get the selected Input.	
Response	Acceptable	"%1" [CR]
	%1	"1" = Computer 1 is selected "2" = Computer 2 is selected "3" = Video is selected
	Unacceptable	"?" [CR]

#### 7.5. Lamp Time Read Command

Command	"CR3" [CR]	
Detail	Get the total lamp running hours (corresponding value).	
Response	Acceptable	"%1" [CR]
	%1	Shows the time period with 5 digits numbers. Example : "00410"[CR] ... shows 410 hours
	Unacceptable	"?" [CR]

#### 7.6. Setting Read Command

Command	"CR4" [CR]	
Detail	Get the screen setting status such as Ceiling / Rear.	
Response	Acceptable	"%1" [CR]
	%1	"11"[CR] = Normal Screen Setting "10" [CR] = Picture is top/bottom reversed. (Status: Rear & Ceiling ON) "01" [CR] = Picture is left/right reversed. (Status: Rear ON) "00" [CR] = Picture is top/bottom and left/right reversed. (Status: Ceiling ON)
	Unacceptable	"?" [CR]

#### 7.7. Temp Read Command

Command	"CR6" [CR]	
Detail	Get the temperature data inside the projector. With some temperature sensors installed in the projector, it is possible to get all the temperature at once.	
Response	Acceptable	"%1_%2_%3" [CR]
	%1 %2 %3	%1 = Temperature of sensor 1 %2 = Temperature of sensor 2 %3 = Temperature of sensor 3 Temperature data is shown as "00.0". When the temperature goes down to -, the first character becomes "-" instead of a space, like "-05.5" [CR]. When no temperature data can be returned due to hardware problems, the first character becomes "E" like "E00.0" [CR]. When several temperature sensors are equipped, Responses are returned continuously. "_ 31.5 _ 35.2 _ 33.4"[CR] The first data is sensor 1, then one space, and the data of sensor 2 follows.
	Unacceptable	"?" [CR]

**7.8. Lamp Mode Read Command**

Command	"CR7" [CR]	
Detail	Get lamp mode status. Single lamp projector can indicate if it is lighting or not.	
Response	Acceptable	"%1" [CR]
	%1	"00" [CR]=Light is out. "01" [CR]=Light is on.
	Unacceptable	" ? "[CR]