

0.7" Wide Video

BASIC SERIAL COMMAND

FUNCTIONAL SPECIFICATIONS

PLV-Z5

CONTENTS

1. Overview	5
2. Serial Interface Specification	5
3. Connection	5
4. Notes for Communication	6
5. Functional Execution Command Table	7
6. Status Read Command Table	9
7. Functional Execution Command	10
7.1. Format	10
7.2. Command Pipelining	10
7.3. Transfer Example	10
7.4. Operation Requirements	11
7.5. POWER ON Command	12
7.6. POWER OFF Command (QUICK POWER OFF)	12
7.7. POWER OFF Command	12
7.8. VIDEO MUTE ON Command	12
7.9. VIDEO MUTE OFF Command	12
7.10. Screen Normal size Command	13
7.11. Screen Full size Command	13
7.12. Image Living Command	13
7.13. Image Creative Cinema Command	13
7.14. Image Pure Cinema Command	13
7.15. Image 1 Command	13
7.16. Image 2 Command	13
7.17. Image 3 Command	14
7.18. Image 4 Command	14
7.19. Image Vivid Command	14
7.20. Image Dynamic Command	14
7.21. Image Brilliant cinema Command	14
7.22. Image Natural Command	14
7.23. MENU ON Command	14
7.24. MENU OFF Command	15
7.25. DISPLAY CLEAR Command	15
7.26. Video Source VIDEO Command	15
7.27. Video Source S-VIDEO Command	15
7.28. Video Source COMPONENT 1 Command	15
7.29. Video Source COMPONENT 2 Command	15
7.30. Power Management ON Command	16
7.31. Power Management OFF Command	16
7.32. Screen Zoom size Command	16

7.33.	Screen Natural wide size 1 Command	16
7.34.	Screen Natural wide size 2 Command	16
7.35.	Point Right Command	16
7.36.	Point Left Command	17
7.37.	Point Up Command.....	17
7.38.	Point Down Command.....	17
7.39.	ENTER Command	17
7.40.	RESET Command	17
7.41.	FREEZE ON Command.....	17
7.42.	FREEZE OFF Command	18
7.43.	Computer Source Analog RGB Command	18
7.44.	Computer Source Scart Command	18
7.45.	HDMI 1 Command	18
7.46.	HDMI 2 Command	18
7.47.	Screen Caption IN Command	18
7.48.	Screen Full through size Command.....	18
7.49.	Screen Normal through size Command.....	19
7.50.	D4 control ON Command	19
7.51.	D4 control OFF Command	19
7.52.	Lamp mode AUTO 1 Command	19
7.53.	Lamp mode AUTO 2 Command	19
7.54.	Lamp mode NORMAL Command.....	19
7.55.	Lamp mode ECO Command	19
7.56.	Ceiling ON Command	20
7.57.	Ceiling OFF Command	20
7.58.	Rear ON Command	20
7.59.	Rear OFF Command	20
7.60.	Logo OFF Command	20
7.61.	Logo Default Command	20
7.62.	Logo User Command.....	20
7.63.	Logo Capture Command	21
7.64.	AUTO PC Adjust Command	21
7.65.	KEYSTONE Command.....	21
7.66.	KEYSTONE Command.....	21
8.	Status Read Command.....	22
8.1.	Format	22
8.2.	Transfer Example.....	22
8.3.	Status Read Command	23
8.4.	Input Mode Read Command	26
8.5.	Lamp Time Read Command	26

8.6. Setting Read Command	26
8.7. Temp Read Command	27

1. Overview

- 1.1 These specifications define projector control commands for PLV-Z5 (0.7" Wide Video Model).
- 1.2 The projector control commands are used to control a projector through RS-232C from a computer.

2. Serial Interface Specification

Items	Specification
Synchronous system	Asynchronous
Transmission Speed	9600 / 19200
Data Length	8 bit
Parity	N/A
Stop Bit	1
Flow Control	N/A

- 1) Transmission speed: initial setting value is 19200.
- 2) Transmission speed can be changed in service mode.

3. Connection

Dedicated serial cable must be used for a connection to a computer and a projector.

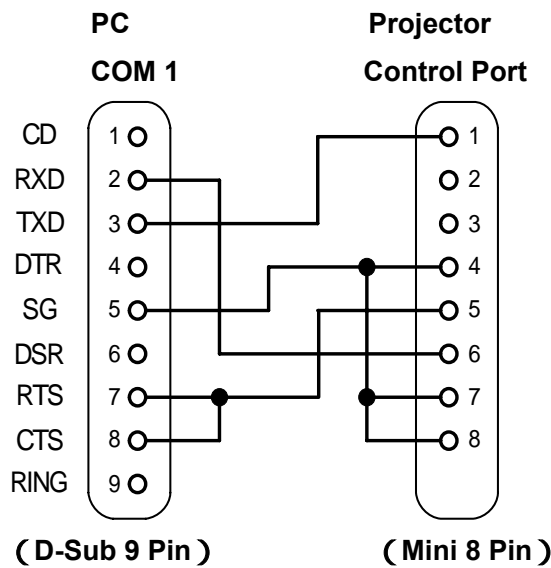

4. Notes for Communication

4.1 The projector command is defined as one command/one line that starts with “C” and ends with carriage return (0x0D).

4.2 When the projector receives carriage return, it starts decoding.

4.3 There are two types of commands: Functional Execution Commands and Status Read Commands.

Example of Functional Execution Command: “C05” [CR]

Example of Status Read Command: “CR0” [CR]

4.4 It clears the information of buffer as below.

4.4.1 The projector receives LF (0x0A) or EOF (0x1A).

4.4.2 When it takes more than one second to receive one command.

(Until the projector returns carriage return since it has received the first data.)

4.5 When control command pipelining, wait the interval of time after the response as below.

4.5.1 [VOLUME +/-] Commands \longrightarrow 100ms

4.5.2 Other Commands \longrightarrow 500ms

4.6 When Status Read command pipelining, wait at least 500ms after the response.

4.7 Do not issue any command before receiving the response except there is no response for 5 seconds.

4.8 It takes about 7 seconds for the internal initialization after plugging in AC. During this time, it cannot process commands. Do not issue any command.

4.9 For 7 seconds after Power ON from Standby, the projector receives a command and returns the response but does not execute it because of the internal initialization or Lamp processing. However, Status Read Commands are carried out after 500 ms when receiving the response to Power ON command.

4.10 About Count Down and the performance during Cooling Down:

When receiving a command during Count Down after Power ON or Cooling Down after Power OFF, the projector returns the response but does not carry it out. However, Status Read Commands are carried out.

4.11 The performance for switching Input:

It takes 5 seconds to switch Input after receiving the command. When receiving the command during this time, it is not executed. However, Status Read Commands are carried out after 500ms since it receives the response to switching Input command.

4.12 The number of character of response to Status Read Commands depends on commands. Please see [8. Status Read Commands].

4.13 Characters for commands must be Capital (A - Z).

5. Functional Execution Command Table

Command	Item	Command	Item
C00	POWER ON	C28	-----
C01	POWER OFF (QUICK POWER OFF)	C29	-----
C02	POWER OFF	C2A	Power Management ON
C03	-----	C2B	Power Management OFF
C04	-----	C2C	Screen Zoom size
C05	-----	C2D	Screen Natural wide 1
C06	-----	C2E	Screen Natural wide 2
C07	-----	C2F	-----
C08	-----	C30	-----
C09	-----	C31	-----
C0A	-----	C32	-----
C0B	-----	C33	-----
C0C	-----	C34	-----
C0D	VIDEO MUTE ON	C35	-----
C0E	VIDEO MUTE OFF	C36	-----
C0F	Screen Normal size	C37	-----
C10	Screen Full size	C38	-----
C11	Image Living	C39	-----
C12	Image Creative Cinema	C3A	Point Right
C13	Image Pure Cinema	C3B	Point Left
C14	Image 1	C3C	Point Up
C15	Image 2	C3D	Point Down
C16	Image 3	C3E	-----
C17	Image 4	C3F	ENTER
C18	Image Vivid	C40	RESET
C19	Image Dynamic	C41	-----
C1A	Image Brilliant cinema	C42	-----
C1B	Image Natural	C43	FREEZE ON
C1C	MENU ON	C44	FREEZE OFF
C1D	MENU OFF	C45	-----
C1E	DISPLAY CLEAR	C46	-----
C1F	-----	C47	-----
C20	-----	C48	-----
C21	-----	C49	-----
C22	-----	C4A	-----
C23	Video Source Video	C4B	-----
C24	Video Source S-Video	C4C	-----
C25	Video Source Component 1	C4D	-----
C26	Video Source Component 2	C4E	-----
C27	-----	C4F	-----

“-----” means “No Function”.

Command	Item	Command	Item
C50	Computer (Analog RGB)	C78	Rear ON
C51	Computer (Scart)	C79	Rear OFF
C52	-----	C7A	Logo OFF
C53	HDMI 1	C7B	Logo Default
C54	HDMI 2	C7C	Logo User
C55	-----	C7D	Logo Capture
C56	-----	C7E	-----
C57	-----	C7F	-----
C58	-----	C80	-----
C59	-----	C81	-----
C5A	-----	C82	-----
C5B	-----	C83	-----
C5C	-----	C84	-----
C5D	-----	C85	-----
C5E	-----	C86	-----
C5F	-----	C87	-----
C60	-----	C88	-----
C61	-----	C89	Auto PC Adj.
C62	-----	C8A	-----
C63	Screen Caption IN size	C8B	-----
C64	-----	C8C	-----
C65	Screen Full through size	C8D	-----
C66	Screen Normal through size	C8E	Keystone ↑
C67	D4 control ON	C8F	Keystone ↓
C68	D4 control OFF	C90	-----
C69	-----	C91	-----
C6A	-----	C92	-----
C6B	-----	C93	-----
C6C	-----	C94	-----
C6D	-----	C95	-----
C6E	-----	C96	-----
C6F	-----	C97	-----
C70	-----	C98	-----
C71	-----	C99	-----
C72	Lamp mode Auto 1	C9A	-----
C73	Lamp mode Auto 2	C9B	-----
C74	Lamp mode Normal	C9C	-----
C75	Lamp mode Eco	C9D	-----
C76	Ceiling ON	C9E	-----
C77	Ceiling OFF	C9F	-----
		CDC	-----

“-----” means “No Function”.

6. Status Read Command Table

Command	Item	Memo
CR0	Status Read	
CR1	Input Mode Read	
CR2	-----	
CR3	Lamp Time Read	
CR4	Setting Read	
CR5	-----	
CR6	Temp Read	
CR7	-----	
CR8	-----	
CR9	-----	
CRA	-----	
CRB	-----	
CRC	-----	

“ ” means “No Function”.

7. Functional Execution Command

7.1. Format

7.1.1 PC issues a command in format as below.

"C" [COMMAND] [CR]

Command: two characters (See Basic Functional Execution Command Table)

7.1.2 A projector changes received data to decode and returns a result after being ready to receive next command.

[ACK] [CR]: (0x06, 0x0D) When received Functional Execution Commands.

"?" [CR]: When the received data cannot be decoded.

7.2. Command Pipelining

When some functions need the command pipelining, the performance is the same as that of the remote control.

7.2.1. System: issue any command every 100 ms.

7.2.2. When receiving the appropriate command, the function is executed for 120 ms from the moment.

7.2.3. When receiving the same command continuously within 120 ms, the function is executed for another 120 ms from the moment.

7.2.4. When there is no incoming command after 120 ms, the execution of pipelining is stopped.

7.2.5. When the projector receives other incoming commands within 120ms, the execution of pipelining is stopped.

7.3. Transfer Example

Switch input mode for the projector to Video Mode with Basic Command.

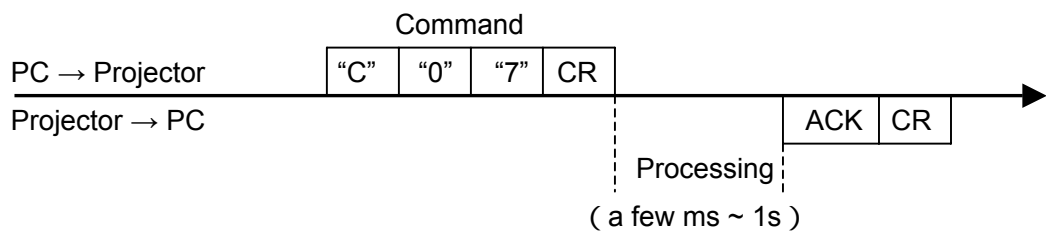

7.4. Operation Requirements

The projector cannot return any response for about two seconds after AC power ON because of the initialization.

When the projector's status is as below, Functional Execution Commands are limited.

(Status Read Commands are available in this status except Standby Mode)

Projector Mode	Available Functional Execution Commands
Super Standby Mode	Impossible to respond
Normal Standby Mode	CR6 : Temperature information read command is unavailable (Commands related to S5V series are also unavailable)
Processing Cooling Down	C00 : POWER ON (Countdown is terminated)
Cooling Down due to Abnormal Temperature	NONE
Abnormal Temperature Status	NONE
Switching Mode	NONE
Processing Power Save / Cooling Down	NONE
Processing Logo Capture / Displaying Captured Logo	NONE
Power Save Status	Only key operation commands are available

Note) 1) When the status is above, even if the projector receives other commands, it returns

[ACK] [CR].

2) Super Standby mode is set as Factory Default and impossible to control by RS232C while the projector is turned OFF. Make sure to switch from Service Mode to Normal Standby Mode as below.

(However, more standby energy is consumed in Normal Standby Mode.)

Group : 100 Item : 4 (Super Standby mode)

0 : Normal Standby Mode

1 : Super Standby Mode (Factory Default)

7.5. POWER ON Command

COMMAND	"C00" [CR]	
Details	Power ON When already Power is ON, no need to do When sending this command during processing Countdown, Countdown is terminated	
Response	Acceptable	[ACK] [CR]
	Unacceptable	" ? "[CR]

7.6. POWER OFF Command (QUICK POWER OFF)

Command	"C01" [CR]	
Details	Power OFF (Standby) When Power is OFF with ON-OFF button of the projector and remote control, "Power Off?" is displayed. However, as soon as this command is sent, Quick Power OFF is executed	
Response	Acceptable	[ACK] [CR]
	Unacceptable	"?"[CR]

7.7. POWER OFF Command

Command	"C02"[CR]	
Details	Power OFF (Standby) When Power is OFF with ON-OFF button of the projector and remote control, "Power OFF" is displayed (When sending this command, "Power OFF?" is displayed. When resending this command during this time, Power OFF is executed)	
Response	Acceptable	[ACK] [CR]
	Unacceptable	"?"[CR]

7.8. VIDEO MUTE ON Command

Command	"C0D"[CR]	
Details	Black out an image The same operation as "NO SHOW" button of the remote control for No Show On, but it does not work for No Show OFF	
Response	Acceptable	[ACK] [CR]
	Unacceptable	"?"[CR]

7.9. VIDEO MUTE OFF Command

Command	"C0E"[CR]	
Details	Restore an image The same operation as "No Show " button of the remote control for No Show Off, but it does not work for No Show On	
Response	Acceptable	[ACK] [CR]
	Unacceptable	"?"[CR]

7.10. Screen Normal size Command

Command	"C0F"[CR]	
Details	Set Computer / Video screen size to Normal	
Response	Acceptable	[ACK] [CR]
	Unacceptable	"?"[CR]

7.11. Screen Full size Command

Command	"C10"[CR]	
Details	Set Computer / Video screen size to Full screen	
Response	Acceptable	[ACK] [CR]
	Unacceptable	"?"[CR]

7.12. Image Living Command

Command	"C11"[CR]	
Details	Set Image to Living Mode	
Response	Acceptable	[ACK] [CR]
	Unacceptable	"?"[CR]

7.13. Image Creative Cinema Command

Command	"C12"[CR]	
Details	Set Image to Creative Cinema Mode	
Response	Acceptable	[ACK] [CR]
	Unacceptable	"?"[CR]

7.14. Image Pure Cinema Command

Command	"C13"[CR]	
Details	Set Image to Pure Cinema Mode	
Response	Acceptable	[ACK] [CR]
	Unacceptable	"?"[CR]

7.15. Image 1 Command

Command	"C14"[CR]	
Details	Set Image to User Image 1 Mode	
Response	Acceptable	[ACK] [CR]
	Unacceptable	"?"[CR]

7.16. Image 2 Command

Command	"C15"[CR]	
Details	Set Image to User Image 2 Mode	
Response	Acceptable	[ACK] [CR]
	Unacceptable	"?"[CR]

7.17. Image 3 Command

Command	"C16"[CR]	
Details	Set Image to User Image 3 Mode	
Response	Acceptable	[ACK] [CR]
	Unacceptable	"?"[CR]

7.18. Image 4 Command

Command	"C17"[CR]	
Details	Set Image to User Image 4 Mode	
Response	Acceptable	[ACK] [CR]
	Unacceptable	"?"[CR]

7.19. Image Vivid Command

Command	"C18"[CR]	
Details	Set Image to Graphics Mode	
Response	Acceptable	[ACK] [CR]
	Unacceptable	"?"[CR]

7.20. Image Dynamic Command

Command	"C19"[CR]	
Details	Set Image to Dynamic Mode	
Response	Acceptable	[ACK] [CR]
	Unacceptable	"?"[CR]

7.21. Image Brilliant cinema Command

Command	"C1A"[CR]	
Details	Set Image to Brilliant cinema Mode	
Response	Acceptable	[ACK] [CR]
	Unacceptable	"?"[CR]

7.22. Image Natural Command

Command	"C1B"[CR]	
Details	Set Image to Natural Mode	
Response	Acceptable	[ACK] [CR]
	Unacceptable	"?"[CR]

7.23. MENU ON Command

Command	"C1C"[CR]	
Details	Display Menu of On Screen Display	
Response	Acceptable	[ACK] [CR]
	Unacceptable	"?"[CR]

7.24. MENU OFF Command

Command	"C1D"[CR]	
Details	Clear Menu of On Screen Display	
Response	Acceptable	[ACK] [CR]
	Unacceptable	"?"[CR]

7.25. DISPLAY CLEAR Command

Command	"C1E"[CR]	
Details	Clear On Screen Display. Clear all On Screen Display unconditionally	
Response	Acceptable	[ACK] [CR]
	Unacceptable	"?"[CR]

7.26. Video Source VIDEO Command

Command	"C23"[CR]	
Details	Set Input Source to Video	
Response	Acceptable	[ACK] [CR]
	Unacceptable	"?"[CR]

7.27. Video Source S-VIDEO Command

Command	"C24"[CR]	
Details	Set Input Source to S-Video	
Response	Acceptable	[ACK] [CR]
	Unacceptable	"?"[CR]

7.28. Video Source COMPONENT 1 Command

Command	"C25"[CR]	
Details	Set Input Source to Component 1	
Response	Acceptable	[ACK] [CR]
	Unacceptable	"?"[CR]

7.29. Video Source COMPONENT 2 Command

Command	"C26"[CR]	
Details	Set Input Source to Component 2	
Response	Acceptable	[ACK] [CR]
	Unacceptable	"?"[CR]

7.30. Power Management ON Command

Command	"C2A"[CR]	
Details	Set Power Management to ON The status by this command is stored in EEPROM and its setting is effective even after POWER ON/OFF	
Response	Acceptable	[ACK] [CR]
	Unacceptable	"?"[CR]

7.31. Power Management OFF Command

Command	"C2B"[CR]	
Details	Set Power Management to OFF The status by this command is stored in EEPROM and its setting is effective even after POWER ON/OFF	
Response	Acceptable	[ACK] [CR]
	Unacceptable	"?"[CR]

7.32. Screen Zoom size Command

Command	"C2C"[CR]	
Details	Set Computer / Video screen size to Zoom	
Response	Acceptable	[ACK] [CR]
	Unacceptable	"?"[CR]

7.33. Screen Natural wide size 1 Command

Command	"C2D"[CR]	
Details	Set Computer / Video screen size to Natural wide 1	
Response	Acceptable	[ACK] [CR]
	Unacceptable	"?"[CR]

7.34. Screen Natural wide size 2 Command

Command	"C2E"[CR]	
Details	Set Computer / Video screen size to Natural wide 2	
Response	Acceptable	[ACK] [CR]
	Unacceptable	"?"[CR]

7.35. Point Right Command

Command	"C3A"[CR]	
Details	Move Pointer of On Screen Display Menu to the right This command performs the same operation as the right-pointing button (">") of the projector	
Response	Acceptable	[ACK] [CR]
	Unacceptable	"?"[CR]

7.36. Point Left Command

Command	"C3B"[CR]	
Details	Move Pointer of On Screen Display to the left This command performs the same operation as the left-pointing button ("<") of the projector	
Response	Acceptable	[ACK] [CR]
	Unacceptable	"?"[CR]

7.37. Point Up Command

Command	"C3C"[CR]	
Details	Move Up Pointer of On Screen Display This command performs the same operation as the upward pointer of the projector	
Response	Acceptable	[ACK] [CR]
	Unacceptable	"?"[CR]

7.38. Point Down Command

Command	"C3D"[CR]	
Details	Move Down Pointer of On Screen Display This command performs the same operation as the downward pointer of the projector	
Response	Acceptable	[ACK] [CR]
	Unacceptable	"?"[CR]

7.39. ENTER Command

Command	"C3F"[CR]	
Details	The same operation as "SELECT" button of the projector and remote control	
Response	Acceptable	[ACK] [CR]
	Unacceptable	"?"[CR]

7.40. RESET Command

Command	"C40"[CR]	
Details	The same operation as "RESET" button of the remote control	
Response	Acceptable	[ACK] [CR]
	Unacceptable	"?"[CR]

7.41. FREEZE ON Command

Command	"C43"[CR]	
Details	Freeze the screen. This command works the same as "FREEZE" button of the remote control for Freeze ON, but does not work for Freeze OFF.	
Response	Acceptable	[ACK] [CR]
	Unacceptable	"?"[CR]

7.42. FREEZE OFF Command

Command	"C44"[CR]	
Details	Cancel Freeze function. This command works the same as "FREEZE" button of the remote control for Freeze OFF, but does not work for Freeze ON.	
Response	Acceptable	[ACK] [CR]
	Unacceptable	"?"[CR]

7.43. Computer Source Analog RGB Command

Command	"C50"[CR]	
Details	Set Input Source to Computer (Analog RGB)	
Response	Acceptable	[ACK] [CR]
	Unacceptable	"?"[CR]

7.44. Computer Source Scart Command

Command	"C51"[CR]	
Details	Set Input Source to Computer (Scart)	
Response	Acceptable	[ACK] [CR]
	Unacceptable	"?"[CR]

7.45. HDMI 1 Command

Command	"C53"[CR]	
Details	Set Input Source to HDMI1	
Response	Acceptable	[ACK] [CR]
	Unacceptable	"?"[CR]

7.46. HDMI 2 Command

Command	"C54"[CR]	
Details	Set Input Source to HDMI2	
Response	Acceptable	[ACK] [CR]
	Unacceptable	"?"[CR]

7.47. Screen Caption IN Command

Command	"C63"[CR]	
Details	Set Computer / Video screen size to Caption IN	
Response	Acceptable	[ACK] [CR]
	Unacceptable	"?"[CR]

7.48. Screen Full through size Command

Command	"C65"[CR]	
Details	Set Computer / Video screen size to Full through	
Response	Acceptable	[ACK] [CR]
	Unacceptable	"?"[CR]

7.49. Screen Normal through size Command

Command	"C66"[CR]	
Details	Set Computer / Video screen size to Normal through	
Response	Acceptable	[ACK] [CR]
	Unacceptable	"?"[CR]

7.50. D4 control ON Command

Command	"C67"[CR]	
Details	Set D4 terminal control function (controlling image identifying signal) to ON	
Response	Acceptable	[ACK] [CR]
	Unacceptable	"?"[CR]

7.51. D4 control OFF Command

Command	"C68"(CR)	
Details	Set D4 terminal control function (controlling image identifying signal) to OFF	
Response	Acceptable	[ACK] [CR]
	Unacceptable	"?"(CR)

7.52. Lamp mode AUTO 1 Command

Command	"C72" [CR]	
Details	Set Lamp Mode to Auto 1 Mode	
Response	Acceptable	[ACK] [CR]
	Unacceptable	"?"(CR)

7.53. Lamp mode AUTO 2 Command

Command	"C73" [CR]	
Details	Set Lamp Mode to Auto 2 Mode	
Response	Acceptable	[ACK] [CR]
	Unacceptable	"?"(CR)

7.54. Lamp mode NORMAL Command

Command	"C74" [CR]	
Details	Set Lamp Mode to Normal	
Response	Acceptable	[ACK] [CR]
	Unacceptable	" ? "(CR)

7.55. Lamp mode ECO Command

Command	"C75" [CR]	
Details	Set Lamp Mode to Eco	
Response	Acceptable	[ACK] [CR]
	Unacceptable	"?"[CR]

7.56. Ceiling ON Command

Command	"C76"[CR]	
Details	Set screen setting to Ceiling ON	
Response	Acceptable	[ACK] [CR]
	Unacceptable	"?"[CR]

7.57. Ceiling OFF Command

Command	"C77"[CR]	
Details	Set screen setting to Ceiling OFF	
Response	Acceptable	[ACK] [CR]
	Unacceptable	"?"[CR]

7.58. Rear ON Command

Command	"C78"(CR)	
Details	Set screen setting to Rear ON	
Response	Acceptable	[ACK] [CR]
	Unacceptable	"?"(CR)

7.59. Rear OFF Command

Command	"C79"(CR)	
Details	Set screen setting to Rear OFF	
Response	Acceptable	[ACK] [CR]
	Unacceptable	"?"(CR)

7.60. Logo OFF Command

Command	"C7A"(CR)	
Details	Set Logo to OFF	
Response	Acceptable	[ACK] [CR]
	Unacceptable	"?"[CR]

7.61. Logo Default Command

Command	"C7B"[CR]	
Details	Set Logo to Default	
Response	Acceptable	[ACK] [CR]
	Unacceptable	"?"[CR]

7.62. Logo User Command

Command	"C7C"[CR]	
Details	Set Logo to User	
Response	Acceptable	[ACK] [CR]
	Unacceptable	"?"[CR]

7.63. Logo Capture Command

Command	"C7D"[CR]	
Details	Capture current image as Logo image	
Response	Acceptable	[ACK] [CR]
	Unacceptable	"?"[CR]

7.64. AUTO PC Adjust Command

Command	"C89"[CR]	
Details	Execute Auto PC Adj. operation This command performs the same operation as "Auto PC Adj." of Menu. When this command is sent during Auto PC Adj. operation, Auto PC Adj. is suspended. The same operation as "AUTO PC" button of RC	
Response	Acceptable	[ACK] [CR]
	Unacceptable	"?"[CR]

7.65. KEYSTONE ↑ Command

Command	"C8E"[CR]	
Details	Correct keystone distortion. Make the screen image length at the top edge shorter (with small range).	
Response	Acceptable	[ACK] [CR]
	Unacceptable	"?"[CR]

7.66. KEYSTONE ↓ Command

Command	"C8F"[CR]	
Details	Correct keystone distortion. Make the screen image length at the bottom edge shorter.	
Response	Acceptable	[ACK] [CR]
	Unacceptable	"?"[CR]

8. Status Read Command

8.1. Format

8.1.1. PC issue commands in format as below.

"CR"Command **[CR]**

Command: 1 character (See Status Read Command Table)

8.1.2. When a projector receives the appropriate command, it returns a character line as the required data.

Required Data **[CR]**

Required data : A character line (See Status Read Command Table)

8.1.3. When the received data cannot be decoded, the projector returns "?"[CR]

8.2. Transfer Example

Get input mode for projector by basic command

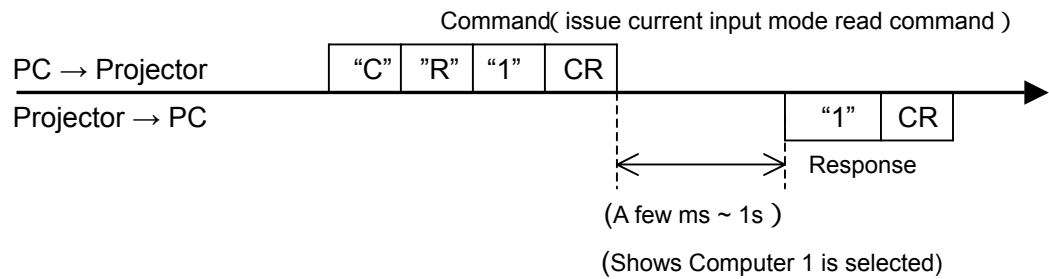

8.3. Status Read Command

Command	"CR0"[CR]	
Details	Get the projector status	
Response	Acceptable	"%1"[CR]
	%1	"00" = Power ON "80" = Standby (Normal Standby) Impossible to respond during Super Standby "40" = Processing Countdown "20" = Processing Cooling down "10" = Power Failure "28" = Processing cooling down due to abnormal temperature "88" = Standby after cooling down due to abnormal temperature Standby due to door failure "24" = Processing Power Save / Cooling down "04" = Power Save "21" = Processing Cooling down after OFF due to lamp failure "81" = Standby after Cooling down due to lamp failure
	Unacceptable	"?"[CR]

【Details for Response】

8.3.1. "00"[CR]

Status: Power ON

Normal image is on-screen.

8.3.2. "80"[CR]

Status: Standby

(This status can be read in only Normal Standby mode, not in Super standby mode)

When the status is normal Standby, Status Read Commands are always available, but Functional Execution Commands are not available except Power ON Command.

8.3.3. "40"[CR]

Status: Processing Countdown

When "Display" in Setting menu is ON and POWER ON is executed, it starts processing Countdown.

When "Display" in Setting menu is OFF, Countdown is canceled and the status moves to Quick Power ON.

8.3.4. "20"[CR]

Status: Processing Cooling down

When the status is Power ON and Power OFF Command ("C01"[CR], "C02"[CR]) is executed, it moves to Cooling down. This status automatically moves to Standby when lamp is turned off and the fan spin finishes after 60 seconds. The fan spin time depends on models.

This function is used to cool down lamps and other optical parts, and is quite important to projector's reliability. During this time, Control Commands are invalid.

8.3.5. "10"[CR]

Status: Power Failure

When the power supply voltage inside the projector reaches abnormal status, the

projector is automatically turned off. The projector returns "10"[CR], which shows it moves to Power OFF status due to power failure.

8.3.6. "28"[CR]

Status: Processing cooling down due to abnormal temperature

When the inside temperature becomes abnormally high, it automatically starts Cooling down. Response for this status is "28"[CR].

Even if the temperature decreases during this process, Cooling down is executed.

8.3.7. "88"[CR]

Status: Standby after Cooling Down due to abnormal temperature

The projector status is restored from abnormal temperature.

When the status moves to Standby after Cooling Down due to abnormal temperature, it returns "88"[CR].

This shows the status turns to Standby because of abnormal temperature and door failure.

This status maintains until next operation is done, When Power On is executed, the information of abnormal temperature is canceled and normal operation is executed.

8.3.8. "24"[CR]

Status: Processing Power Save / Cooling Down

When Power Management function in the Setting menu works and no signal is received for 5 minutes, lamps are turned off and the status goes to Power Save / Cooling Down. (During this time, the green LED of the projector is off)

During this time, Functional Execution Commands are invalid. (Not executed)

The status moves to Power Save at set hours after the operation of Cooling Down.

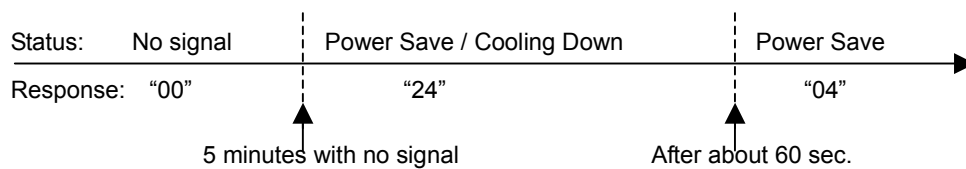

8.3.9. "04"[CR]

Status: Power Save

This shows it moves to Power Save status by Power management function in the Setting menu

8.3.10. "21"[CR]

Status: Processing Cooling Down after OFF due to lamp failure

When a projector is turned off because of lamp failure, it starts Cooling Down automatically. It returns "21"[CR].

The response command "21"[CR] maintains during Cooling Down.

8.3.11. "81"[CR]

Status: Standby after Cooling Down due to lamp failure

When the status moves to Standby after Cooling Down due to lamp failure, it returns

“81” [CR]. This shows the status turns to Standby because of lamp failure. This status stays until next operation is executed.

When Power ON is executed, the information of lamp failure is canceled and normal operation is executed.

8.4. Input Mode Read Command

Command	"CR1"[CR]	
Details	Get the selected Input	
Response	Acceptable	"%1"[CR]
	%1	"0" = Video is selected "1" = S-Video is selected "2" = Component1 is selected "3" = Component2(D4-Video) is selected "4" = HDMI1 is selected "5" = HDMI2 is selected "6" = Computer(Analog) is selected "7" = Computer(Scart) is selected
	Unacceptable	"?"[CR]

8.5. Lamp Time Read Command

Command	"CR3"[CR]	
Details	Get the total lamp running time	
Response	Acceptable	"%1"[CR]
	%1	5-digit character shows the time. Example: "00410"[CR] = 410Hours
	Unacceptable	"?"[CR]

8.6. Setting Read Command

Command	"CR4"[CR]	
Details	Get the screen setting status such as Ceiling / Rear	
Response	Acceptable	"%1"[CR]
	%1	"11"[CR] = Normal Screen Setting "10"[CR] = Picture is top/bottom reversed (Status : Mounting) "01"[CR] = Picture is left/right reversed (Status : Rear) "00"[CR] = Picture is top/bottom and left/right reversed (Status : Ceiling ON)
	Unacceptable	"?"[CR]

8.7. Temp Read Command

Command	"CR6"[CR]	
Details	Get the temperature data inside a projector. With some temperature sensors installed in the projector, it is possible to get all the temperature at once	
Response	Acceptable	"%1_%2_%3"[CR]
	%1 %2 %3	<p>%1 = Temperature of Sensor 1 %2 = Temperature of Sensor 2 %3 = Temperature of Sensor 3</p> <p>Temperature data is shown as "00.0" When the temperature sinks to "-", the first character is "-" like "-05.5"[CR] When the temperature data returns due to hardware problems, the first character is "E" like "E00.0"[CR]</p> <p>When the status is Standby or it is 10 seconds after Power On, temperature may approach the abnormal status due to ballast lamp's residual heat depending on projectors. So, when the status is Standby or it is 10 seconds after Power On, the process for the abnormal temperature is not executed. The temperature data is "□----". When some temperature sensors are installed, the projector sends commands continuously.</p> <p>"□31.5 □□35.2 □□32.8"[CR] There is the sensor 1 data, one space, and the sensor 2 data...</p>
	Unacceptable	"?"[CR]